

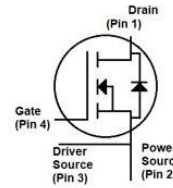

# High Power SiC MOSFET Transistor AMR075V120H1



## Applications:

- Solar Inverters
- Uninterrupted power supplies
- Switch mode power supplies
- Motor drives

## Features:

- High blocking voltage with low on-resistance
- High switching speed with low capacitance
- Very low switching losses
- Excellent avalanche ruggedness
- Very fast and robust intrinsic body diode with low reverse recovery

### Absolute Maximum Ratings ( $T_{amb}=25^{\circ}\text{C}$ , unless specified otherwise)

Symbol	Parameter	AMR075V120H1	Unit
$V_{DS}$	DC Reverse Voltage	1200	V
$V_{GSmax}$	Gate-source voltage, max. transient voltage	-10/+22	
$V_{GSmax}$	Gate-source voltage, max. static voltage	-8/+19	
$V_{GSop}$	Gate-source voltage	-4/ +15	
$I_D$	Continuous drain current ( $V_{GS} = 15\text{V}$ ), $T_C = 25^{\circ}\text{C}$	35	A
	Continuous drain current ( $V_{GS} = 15\text{V}$ ), $T_C = 100^{\circ}\text{C}$	25	
$I_{D(pulse)}$	Pulsed drain current	88	A
$P_{tot}$	Power dissipation	170	W
$T_j$	Operating junction temperature	-55 to 175	$^{\circ}\text{C}$
$T_{stg}$	Storage temperature	-55 to 175	$^{\circ}\text{C}$
$M$	Mounting torque	1	Nm

### Thermal and Mechanical Characteristics

Symbol	Parameter	Test conditions	Min	Typ	Max	Unit
$R_{\theta JC}$	Junction-to-case thermal Resistance		-	0.60	-	$^{\circ}\text{C}/\text{W}$
$R_{\theta JA}$	Junction-to-ambient thermal Resistance		-	-	40	$^{\circ}\text{C}/\text{W}$

**Static Electrical Characteristics ( $T_A = 25^\circ\text{C}$ , unless specified otherwise)**

Symbol	Parameter	Test Conditions	Min	Typ	Max	Unit
$BV_{DSS}$	Drain-Source Breakdown Voltage	$V_{GS} = 0\text{ V}, I_D = 100\ \mu\text{A}$	1200	-	-	V
$V_{GS(th)}$	Gate-Source Threshold Voltage	$V_{DS} = V_{GS}, I_D = 5\text{mA}$	2	3	4	
		$V_{DS} = V_{GS}, I_D = 5\text{mA}, T_J = 175^\circ\text{C}$	-	2	-	
$I_{DSS}$	Drain-Source Leakage current	$V_{DS} = 1200\text{V}, V_{GS} = 0\text{V}$	-	1	50	$\mu\text{A}$
$I_{GSS}$	Gate-Source leakage current	$V_{GS} = 15\text{V}, V_{DS} = 0\text{V}$	-	1	250	nA
$R_{DS(on)}$	Drain-Source ON Resistance	$V_{GS} = 15\text{ V}, I_D = 20\text{A}$	-	72	92	m $\Omega$
		$V_{GS} = 15\text{ V}, I_D = 20\text{A}, T_J = 175^\circ\text{C}$	-	115	-	
$g_{fs}$	Transconductance	$V_{DS} = 20\text{V}, I_D = 20\text{A}$	-	18	-	S
		$V_{DS} = 20\text{V}, I_D = 20\text{A}, T_J = 175^\circ\text{C}$	-	14	-	
$R_{g(int)}$	Internal gate resistance	$f = 1\text{MHz}, V_{AC} = 25\text{mV}$	-	1.4	-	$\Omega$

**Dynamic Characteristics ( $T_A = 25^\circ\text{C}$ , unless specified otherwise)**

Symbol	Parameter	Test conditions	Min	Typ	Max	Unit
$C_{iss}$	Input Capacitance	$V_{GS} = 0\text{V}, V_{DS} = 1000\text{V}, f = 1\text{MHz}, V_{AC} = 25\text{mV}$	-	882	-	pF
$C_{rss}$	Reverse Transfer Capacitance		-	2	-	
$C_{oss}$	Output Capacitance		-	42	-	
$E_{oss}$	$C_{oss}$ stored energy		-	24	-	$\mu\text{J}$
$Q_{gs}$	Gate-Source Gate Charge	$V_{DD} = 800\text{V}, V_{GS} = -4/+15\text{V}, I_D = 20\text{A}, I_{GS} = 1\text{mA}$	-	19	-	nC
$Q_{gd}$	Gate-Drain Gate Charge		-	23	-	
$Q_g$	Total Gate Charge		-	61	-	

**Switching Characteristics ( $T_A = 25\text{ }^\circ\text{C}$ , unless specified otherwise)**

Symbol	Parameter	Test conditions	Min	Typ	Max	Unit	
$T_{d(on)}$	Turn-on delay time	$V_{DD} = 800V,$ $V_{GS} = -4/+15V, I_D = 20A,$ $R_{G(ext)} = 5.1\Omega, L = 110\mu H,$ $T_j = 25^\circ\text{C}$	-	12	-	ns	
$T_r$	Rise time		-	20	-		
$T_{d(off)}$	Turn-off delay time		-	23	-		
$T_f$	Fall time		-	13	-		
$E_{on}$	Turn On Switching Energy		$T_j = 25^\circ\text{C}$	-	321	-	$\mu\text{J}$
$E_{off}$	Turn Off Switching Energy	-		16	-		
$T_{d(on)}$	Turn-on delay time	$V_{DD} = 800V,$ $V_{GS} = -4/+15V, I_D = 20A,$ $R_{G(ext)} = 5.1\Omega, L = 110\mu H,$ $T_j = 175^\circ\text{C}$	-	10	-	ns	
$T_r$	Rise time		-	20	-		
$T_{d(off)}$	Turn-off delay time		-	27	-		
$T_f$	Fall time		-	14	-		
$E_{on}$	Turn On Switching Energy		$T_j = 175^\circ\text{C}$	-	439	-	$\mu\text{J}$
$E_{off}$	Turn Off Switching Energy			-	18	-	

**Body Diode Characteristics ( $T_A = 25\text{ }^\circ\text{C}$ , unless specified otherwise)**

Symbol	Parameter	Test conditions	Min	Typ	Max	Unit
$V_{SD}$	Body Diode Forward Voltage	$V_{GS} = -4V, I_{SD} = 10A$		3.5		V
		$V_{GS} = -4V, I_{SD} = 10A,$ $T_j = 175^\circ\text{C}$		3.1		
$I_S$	Continuous diode forward current	$T_C = 25^\circ\text{C}$	-	-	35	A
$t_{rr}$	Reverse recovery time	$V_{GS} = -4V, I_{SD} = 20A,$	-	12	-	ns
$Q_{rr}$	Reverse recovery charge	$V_R = 800V,$	-	0.22	-	$\mu\text{C}$
$I_{rrm}$	Peak reverse recovery current	$di/dt = 3.84\text{kA}/\mu\text{s},$ $T_j = 25^\circ\text{C}$	-	30	-	A
$t_{rr}$	Reverse recovery time	$V_{GS} = -4V, I_{SD} = 20A,$	-	22	-	ns
$Q_{rr}$	Reverse recovery charge	$V_R = 800V,$	-	0.52	-	$\mu\text{C}$
$I_{rrm}$	Peak reverse recovery current	$di/dt = 3.89\text{kA}/\mu\text{s},$ $T_j = 175^\circ\text{C}$	-	37	-	A

### Electrical Characteristic Diagrams

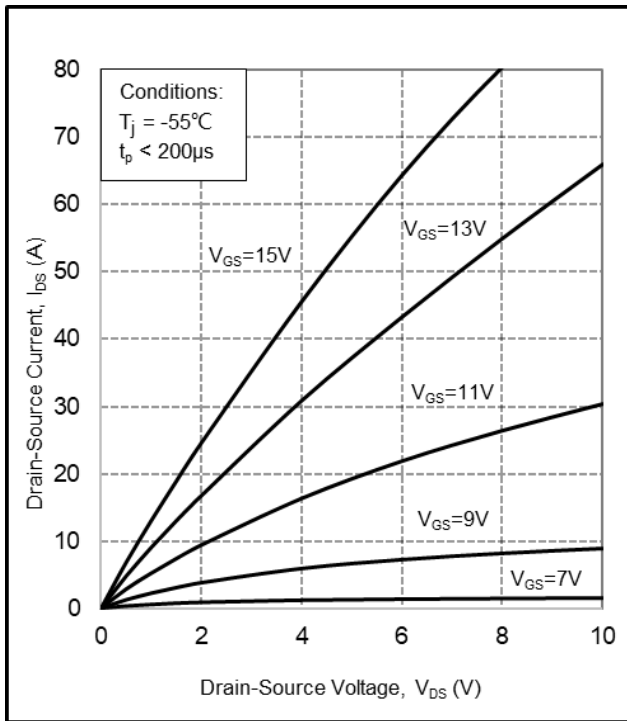

Figure 1. Output characteristics at  $T_j = -55^\circ\text{C}$

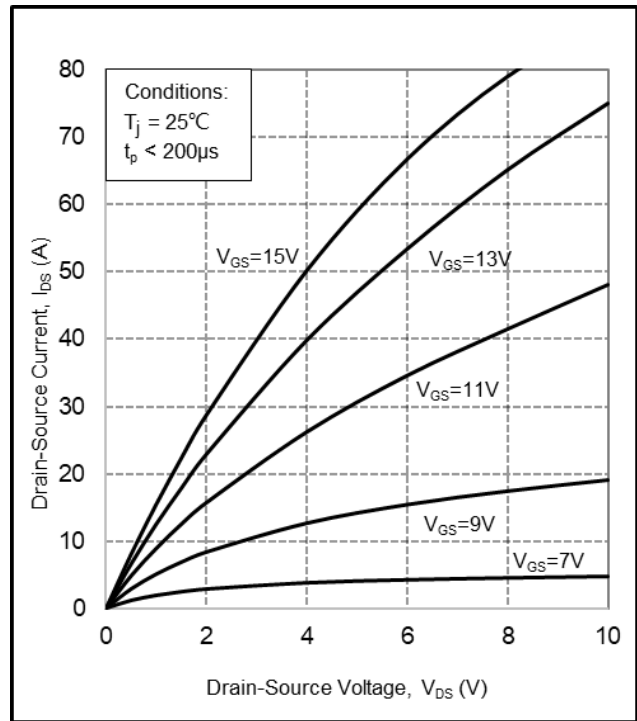

Figure 2. Output characteristics at  $T_j = 25^\circ\text{C}$

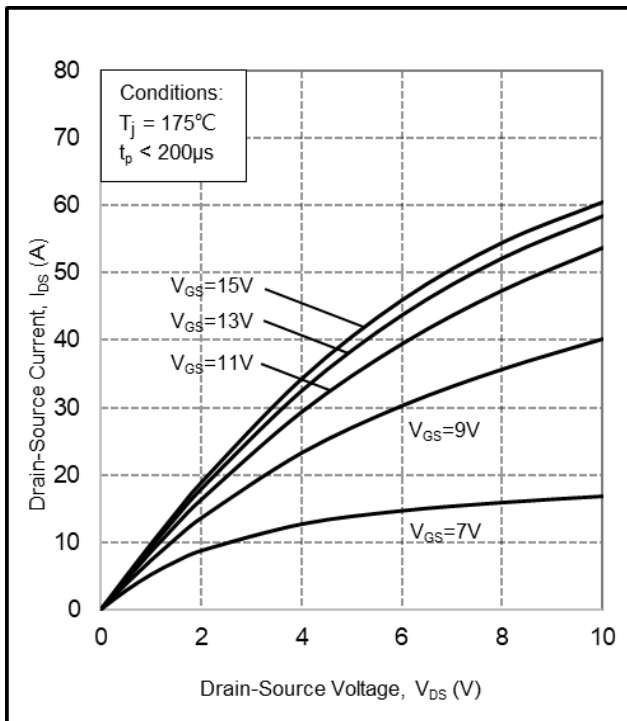

Figure 3. Output characteristics at  $T_j = 175^\circ\text{C}$

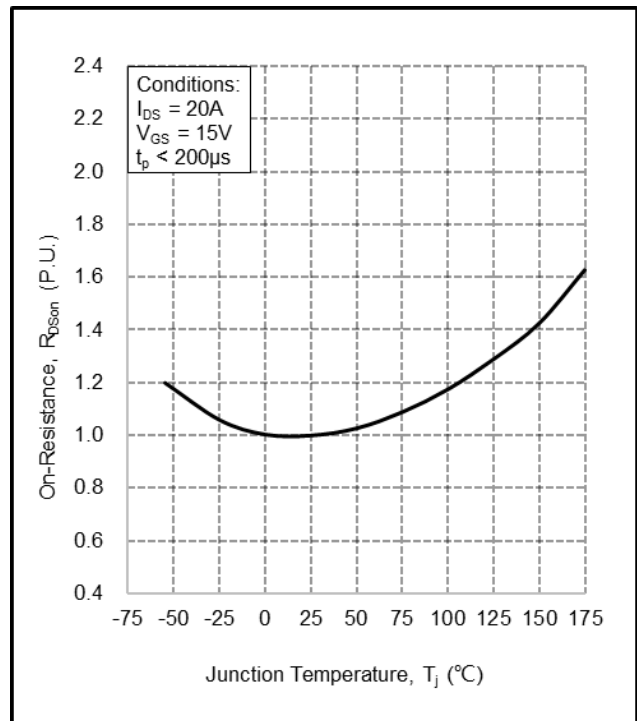

Figure 4. Normalized on-resistance vs. temperature

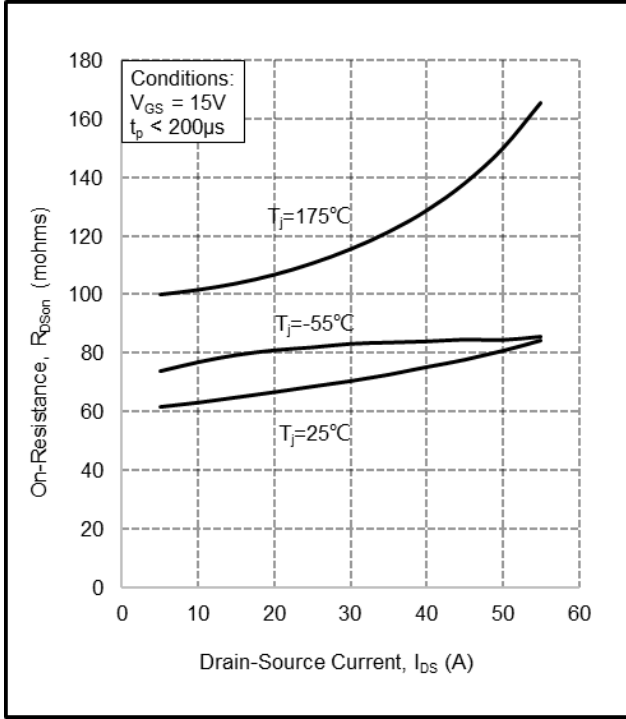

Figure 5. On-resistance vs. drain current for various temperatures

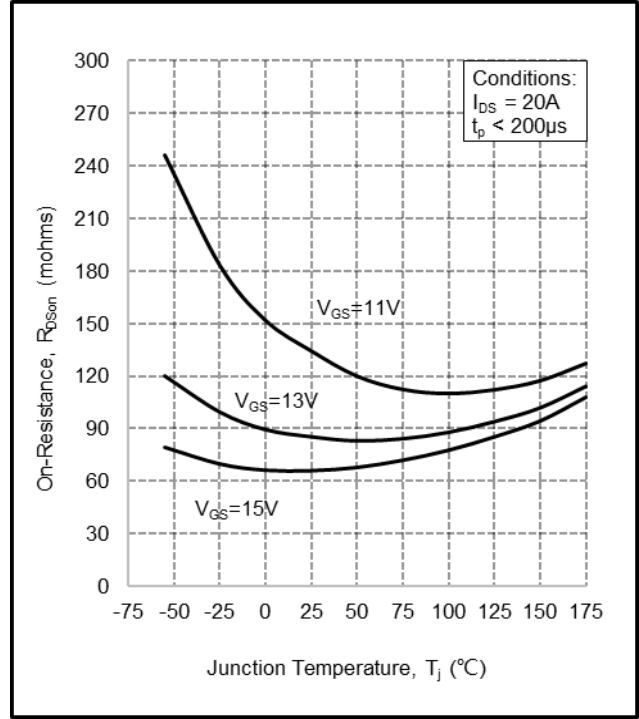

Figure 6. On-resistance vs. temperature for various gate voltages

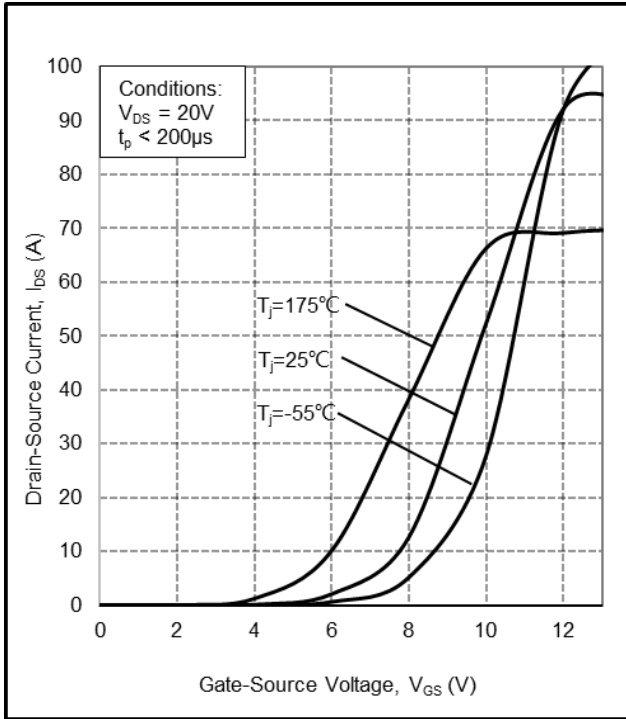

Figure 7. Transfer characteristic for various junction temperatures

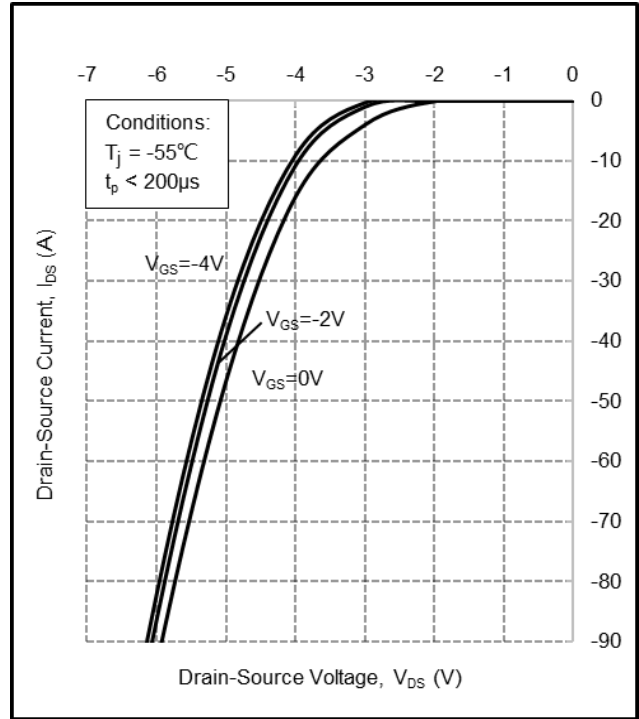

Figure 8. Body diode characteristic at  $T_J = -55^\circ\text{C}$

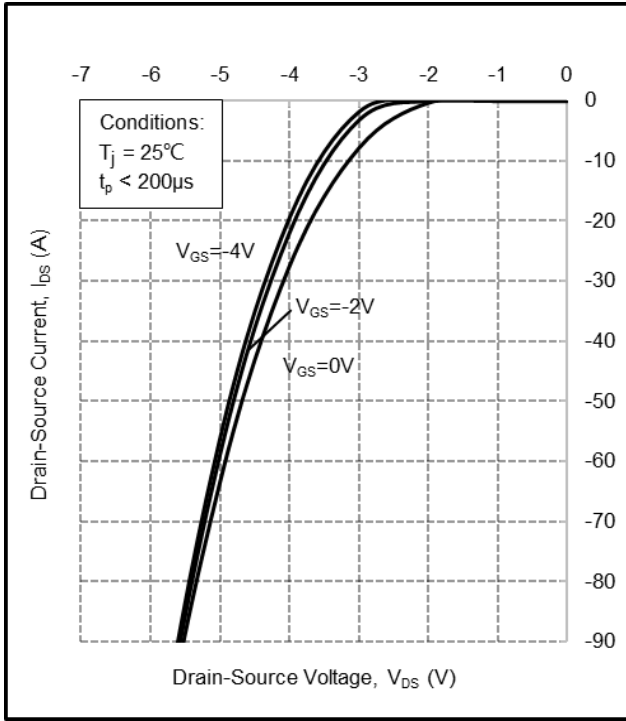

Figure 9. Body diode characteristic at  $T_j = 25^\circ\text{C}$

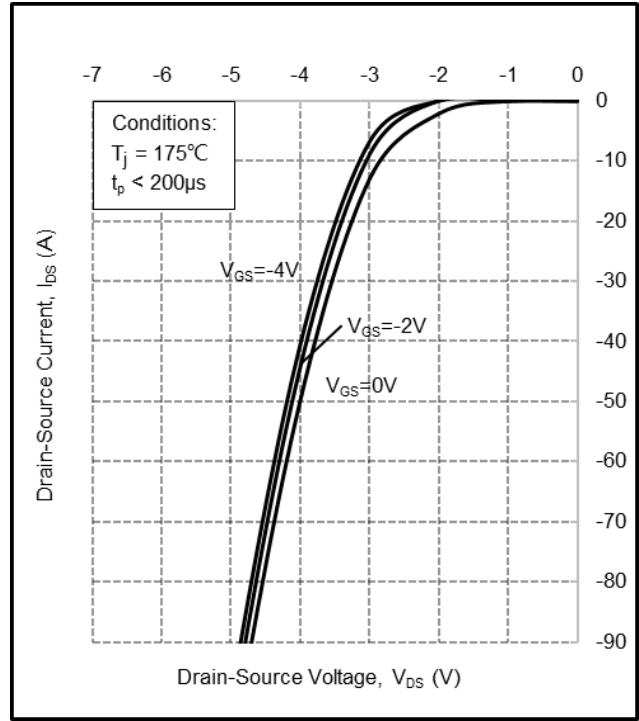

Figure 10. Body diode characteristic at  $T_j = 175^\circ\text{C}$

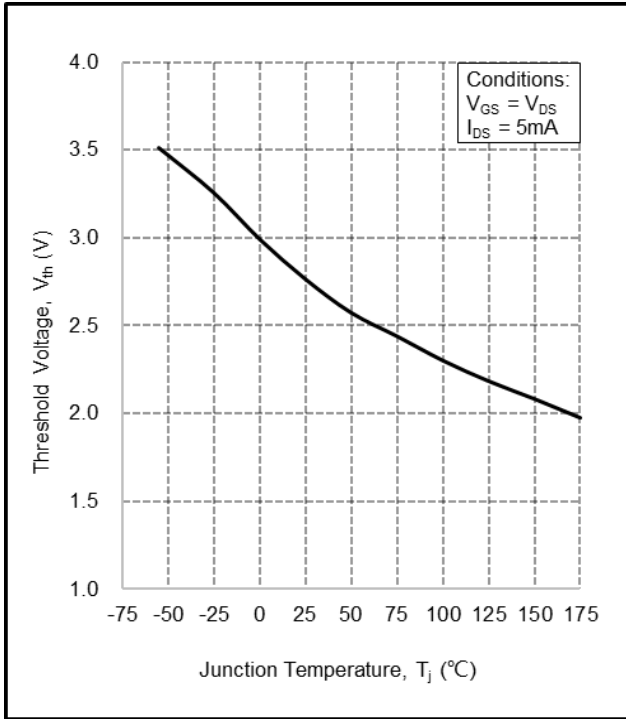

Figure 11. Threshold voltage vs. temperature

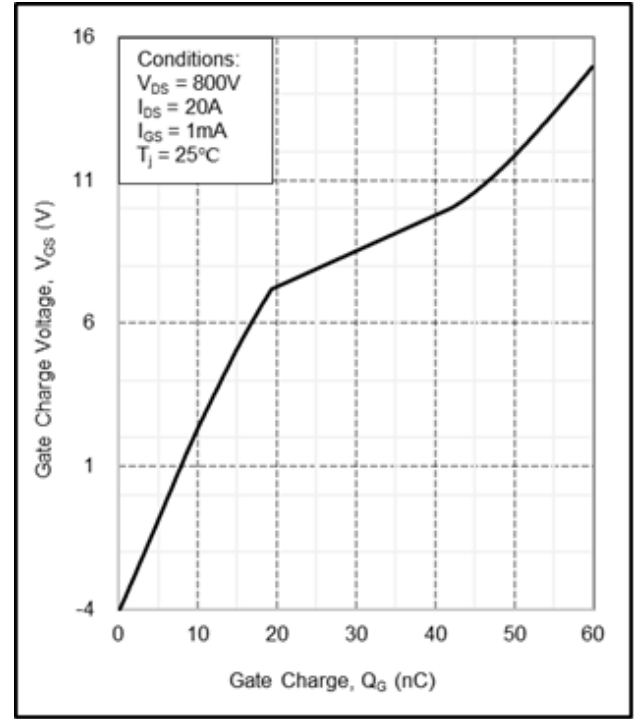

Figure 12. Gate charge characteristics

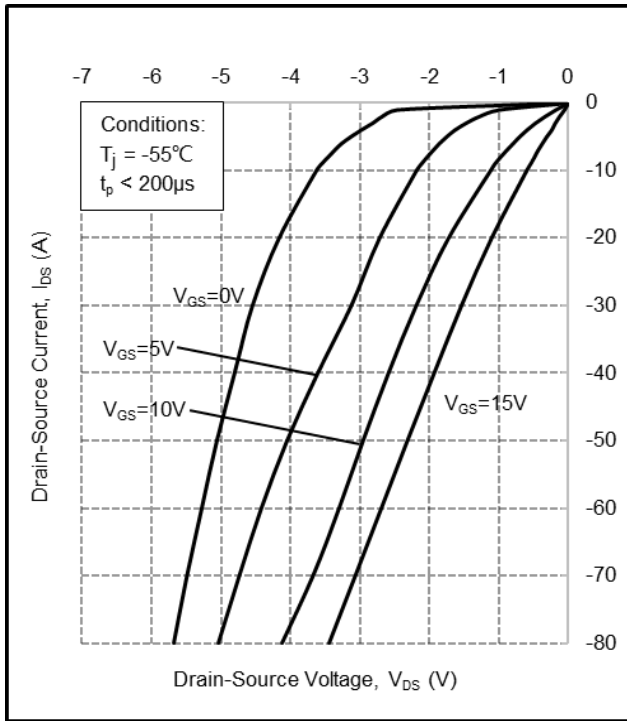

Figure 13. 3rd quadrant characteristic  
at  $T_j = -55^\circ\text{C}$

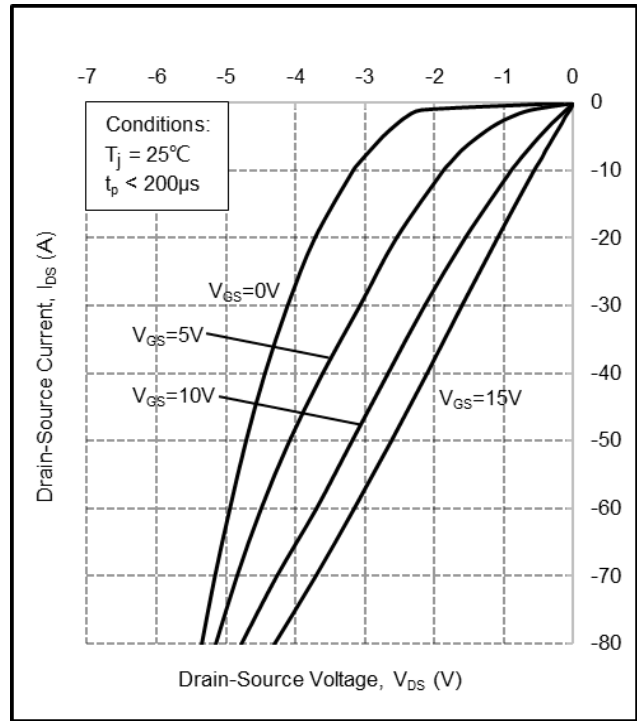

Figure 14. 3rd quadrant characteristic  
at  $T_j = 25^\circ\text{C}$

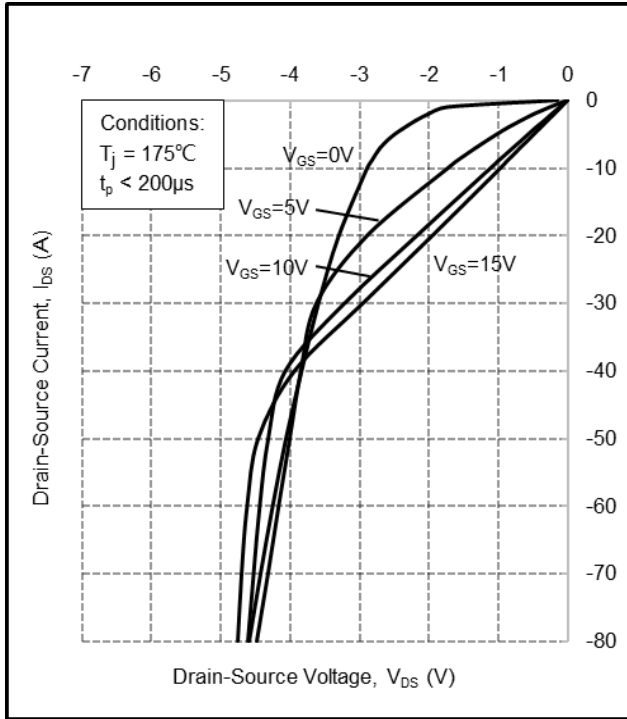

Figure 15. 3rd quadrant characteristic  
at  $T_j = 175^\circ\text{C}$

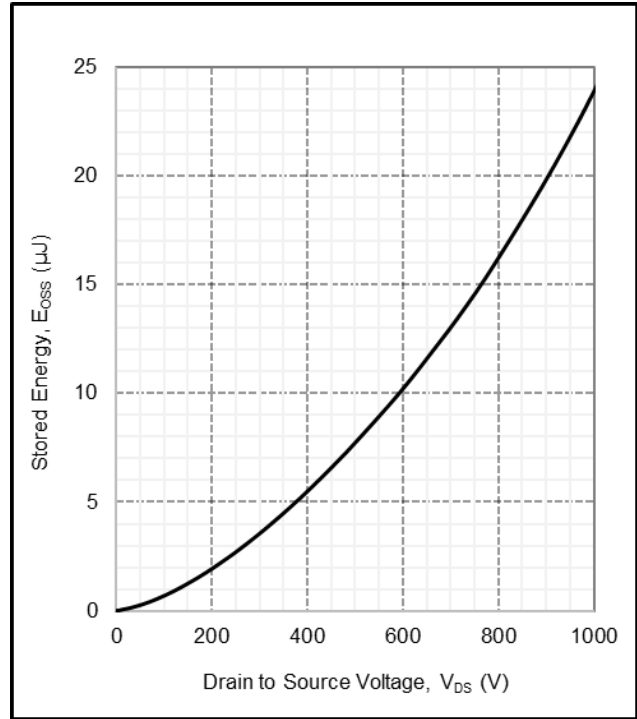

Figure 16. Output capacitor stored energy

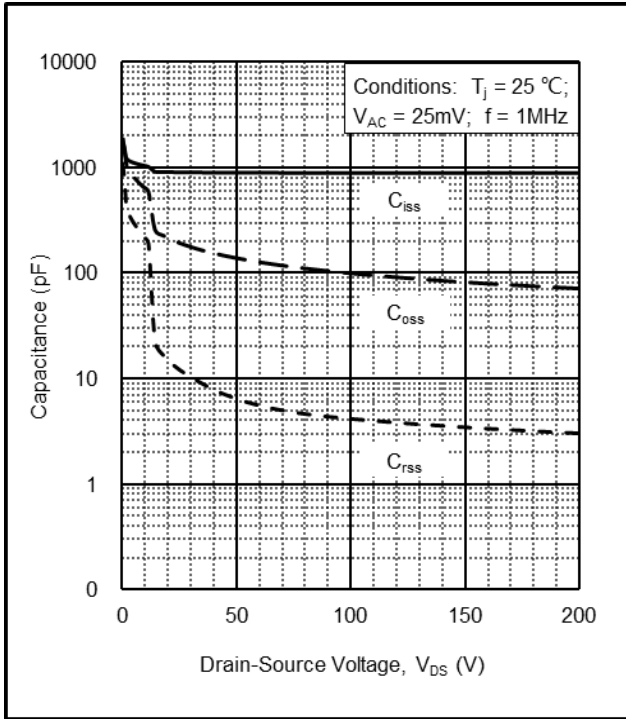

Figure 17. Capacitance vs. drain-source voltage  
(0 - 200V)

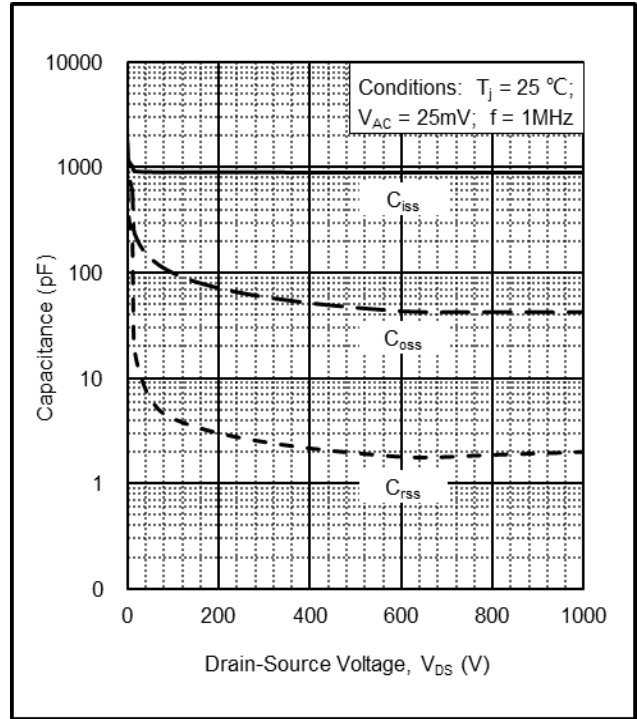

Figure 18. Capacitance vs. drain-source voltage  
(0 - 1000V)

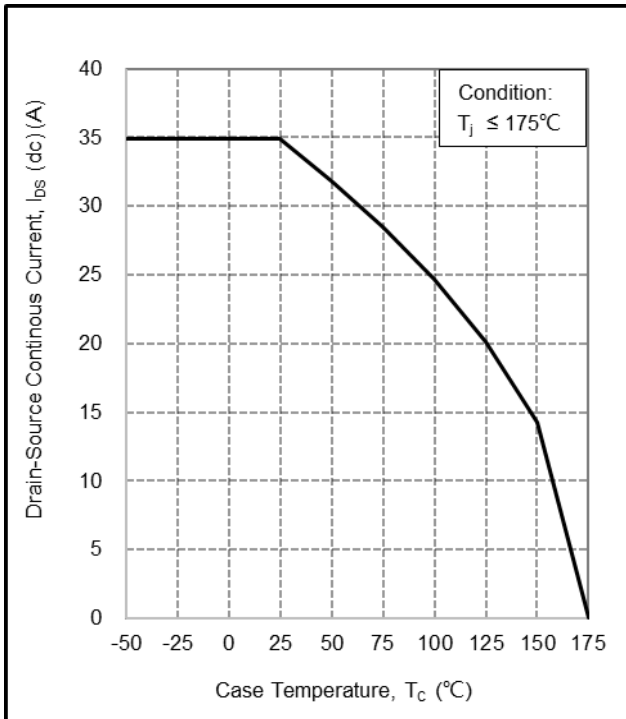

Figure 19. Continuous drain current derating  
vs. temperature

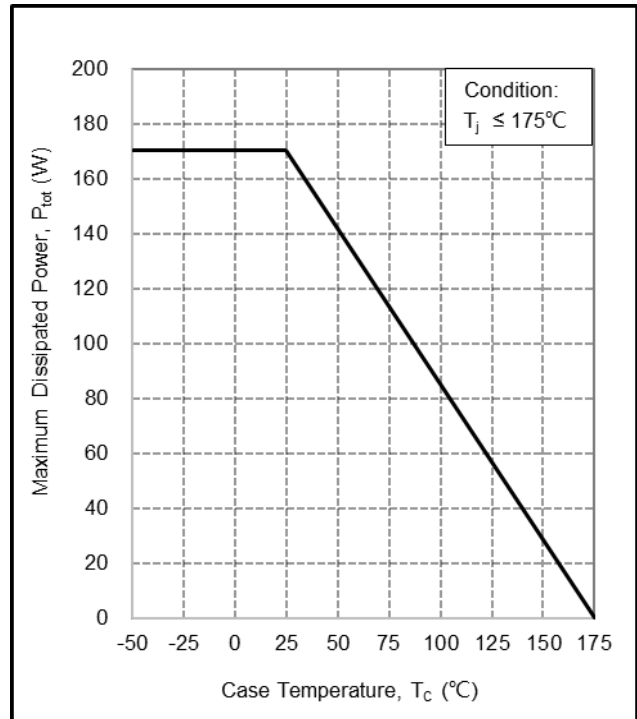

Figure 20. Maximum power dissipation derating  
vs. temperature



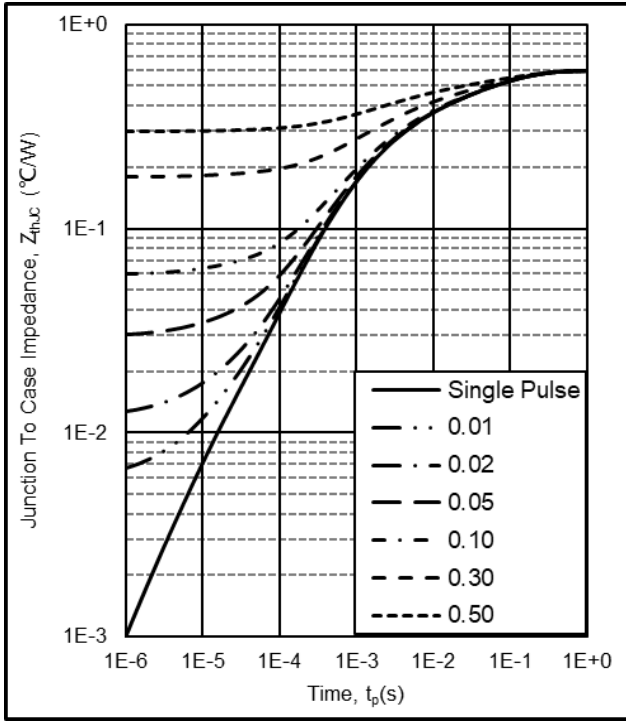

Figure 21. Transient thermal impedance  
(Junction - Case)

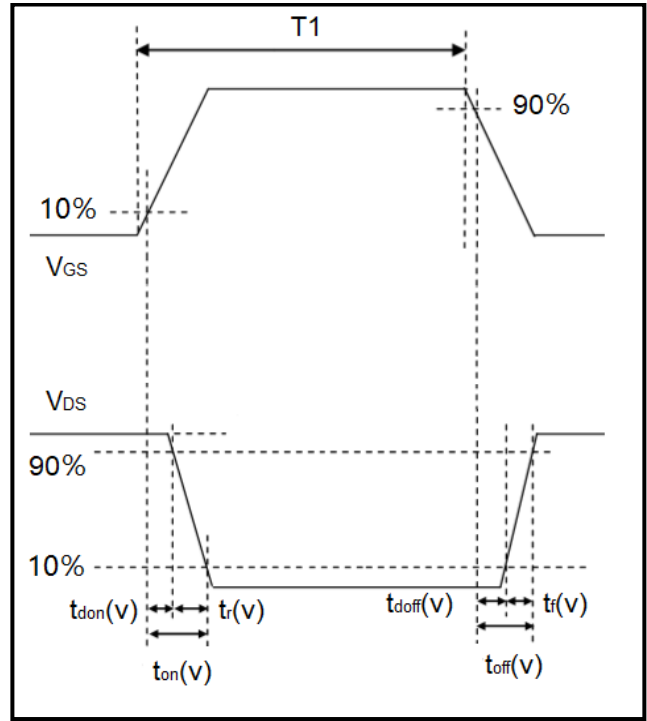

Figure 22. Switching times definition

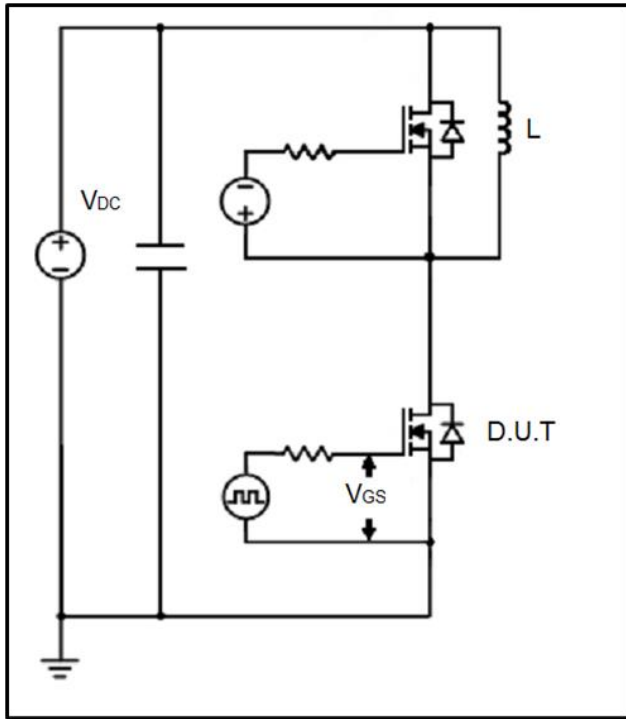
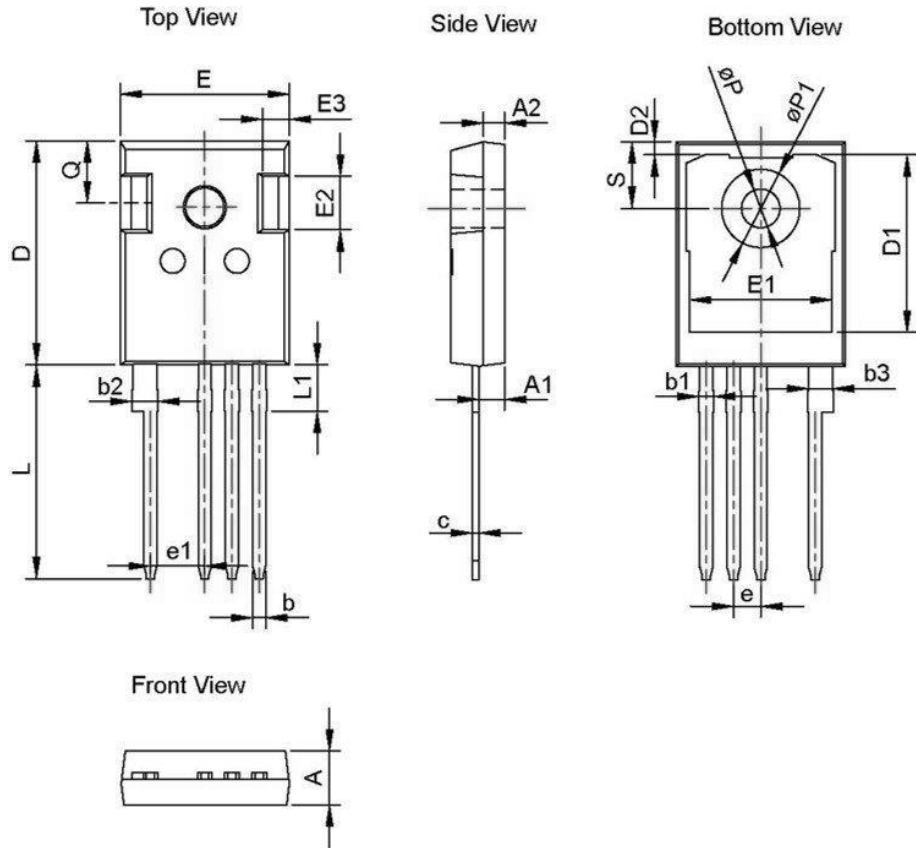

Figure 23. Clamped inductive switching waveform  
test circuit

**Package Information:**



Dimension unit: [mm]			
Symbol	Min	Nom	Max
A	4.80	5.00	5.20
A1	2.21	2.41	2.61
A2	1.85	2.00	2.15
b	1.11	1.21	1.36
b1	1.11	1.37	1.57
b2	2.24	2.40	2.60
b3	2.11	2.21	2.36
c	0.51	0.60	0.75
D	20.70	20.90	21.30
D1	15.92	16.22	16.52
D2	1.00	1.20	1.35
E	15.50	15.80	16.10
E1	13.00	13.30	13.60
E2	4.80	5.00	5.20
E3	2.30	2.50	2.70
e	2.54 BSC		
e1	5.08 BSC		

Dimension unit: [mm]			
Symbol	Min	Nom	Max
L	19.62	19.92	20.22
L1	-	-	4.30
$\phi P$	3.40	3.60	3.80
$\phi P1$	-	-	7.30
Q	5.40	5.80	6.20
S	6.20 BSC		

## Recommended Solder Pad Layout

Note: All dimensions are in mm

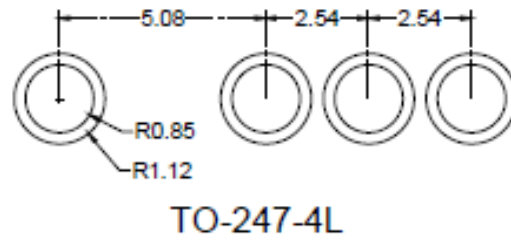

## Ordering Information

Part number	AMR075V120H1
Package	TO-247-4L
Unit quantity	300 EA
Packing type	Tube